

Cast Steel (WCB) Globe Valve

ASA 150#

TECHNICAL DATA

Manufacturing Std	:	BS 1873
Testing & Inspection Std	:	API 598/ BS 5146
Face To Face	:	As per ANSI B16.10
End Connections	:	Flanged as per ANSI B 16.5 RF ASA 150 Class

P. No.	Nomenclature	Qty.	Material
1	Body	1	ASTM A216 Gr. WCB
2	Bonnet	1	ASTM A216 Gr. WCB
3	Seat Ring	1	AISI SS 410
4	Valve	1	AISI SS 410
5	Spindle Nut	1	M.S.
6	Spindle	1	AISI SS 410
7	Gland Flange	1	WCB
8	Yoke Nut	1	M.S.
9	Gasket	1	CAF / GRAPHITE ASBESTOS
10	Eye Bolt and Nut	2	M.S.
11	Bolt and Nut	4	M.S.
12	Gland Packing	4	Graphoil Ring.
13	Hand Wheel	1	C.I.
14	Handwheel Nut	1	M.S.

ASA - 150						
SIE	A	B	C	D	E	F
MM	FI TO FI	OD	RF	PCD	Hole Dia	No of Hole
15	108	89	35	60	15	4
20	118	98	43	70	15	4
25	127	108	51	80	16	4
40	165	127	73	98.5	16	4
50	203	152	92	120.5	19	4
65	216	178	105	140	19	4
80	241	190.5	127	152	19	4
100	292	229	157	190.5	19	8
125	356	254	183	216	22	8
150	406	279	216	241	22	8
200	495	343	270	298	22	8
250	622	406	34	362	25	12
300	698	485	305	432	26	12
350	787	535	413	476	28.5	12

SERVICE RATING & TEST PRESSURE

Class	Working Pressure	Temperature Maximum	Hydraulic Test Pressure	
			Body	Seat
150	10 kg/cm ²	300° C	28 kg/cm ²	21 kg/cm ²

Manufactured By: VALSON VALVES MFG. CO. A'BAD

www.valsonvalves.com

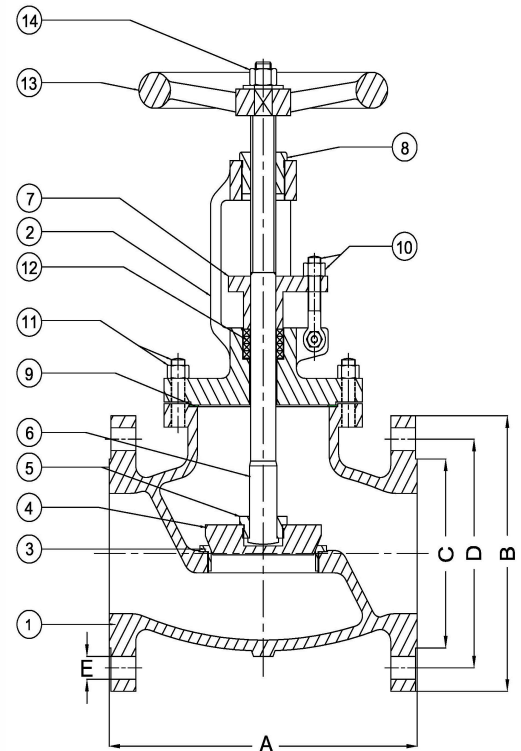

*All Dimensions are in mm.

DEALER